

# Beginners Guide to Small Telescopes – Labs



First Telescope

James Yoder

## Index

---

- [Pre-Lab: Small Sessions](#)
  
- Lab 1: [The Moon](#)
  - Goals of the Lab
  - Terms
  - Observing Session
    - Observing the Moon and the Planets
  - Exercise: The Moon
  - The Planets
  
- Lab 2: [Multiple Star Systems](#)
  - Goals of The Lab
  - Terms
  - Part 1: Using The Planisphere to See What Is Up
  - Part 2: Planning Your Observation Session Walkthrough
    - Exercise
  - Observation Session: Multiple Star Systems
  - 
  - Part 1: Components of a Telescope
    - Exercise 1
  - Part 2: Finding Polaris
    - Exercise 2
  - Part 3: Measurements in the Sky & Planisphere (Star Wheel)
  - Viewing Session
    - Exercise – Finding Constellations
  - Observation Session: The Planets
  
- Lab 3: [Telescope Types and Mounts](#)
  - Goals of the Lab
  - Terms
  - Part 1: Telescope Mount Alignment Procedure
  - Part 2: Finderscope Alignment Procedure
  - Exercise: Planning Your Observation Session

## Index

---

- Lab 4: [Collimation and Techniques for Finding Objects](#)
  - Goals of the Lab
  - Terms
  - Checking Collimation
  - Performing Collimation
  - Exercise: Plan Your Observing Session
  - Observing Session
    - Scope Setup
    - Collimation
    - Techniques for Finding Objects

### 2026-03 Class Moon Data

Date	Site	Lab	% Illum	Rise	Trans	Set
03/27	Gilbert	The Moon	75%	01:31 pm	08:49 pm	03:17am
04/03	Picketpost	Multiple Star Systems	96%	08:45 pm	01:19 am	06:46 am
04/10	Picketpost	Deep Sky	42%	02:05 am	07:03 am	12:04 pm
14/18*	Picketpost	Open Lab	3.4%	06:22 am	01:35 pm	08:57 pm

# Pre-Lab: Small Sessions

---

### Goals of The Lab

One of the most challenging tasks for the beginning amateur astronomer is understanding the various components of their telescope and how to operate it. The intent of the small session is to lay the foundations of the basic operation of your telescope with some one-on-one time.

Before having our regular scheduled labs, we will schedule small group sessions with two to four persons in a group. Persons who don't own a telescope will still benefit from these sessions. The topics of discussion will include:

- Hardware setup and mount basics
- Locating objects in the night sky
- Checking collimation of your telescope
- Discussion on eyepieces

In addition to these topics persons with German Equatorial and Fork Mounts will learn about performing polar alignment for the mount. For persons with GOTO mounts we will try to perform a basic alignment procedure and check on the performance of the GOTO operations once a successful alignment has been completed.

GOTO Mounts – There are a large number of manufactures that create GOTO mounts, and each one has its own set of menus and procedures to perform various tasks such as alignment. It is recommended you review the associated manual before the class since it is possible the instructor may not have experience with your particular mount.

Ideally our sessions will begin in the evening while there is still daylight so it is easier to identify the various components of the telescope. Students are encouraged to bring the manual to their telescope with them for reference in this session (this is a must for persons with GOTO mounts).

# Lab 1: The Moon

---

## Goals of Lab

This week we will be focusing on observing the moon.

## Resources

East Valley Astronomy Club: [Lunar Program](#)

## Terms

Some key [terms](#) and concepts that are important to know for this lab are:

- **Apogee** – The point of the moon's orbit furthest from Earth.
- **Basin** – A large impact crater with a diameter in excess of 100km.
- **Craters** – Indentations that are bowl or saucer shaped in configuration. Formed by impact or geologic activity
- **Escarpment** – A steep slope or long cliff that forms as a result of faulting or erosion and separates two relatively level areas having different elevations.
- **Highlands** – Densely cratered and higher elevated areas of the lunar surface.
- **Lacus** – Small plain.
- **Mare** – Latin for seas. Large dark basaltic planes on the moon formed by ancient asteroid impacts on the far side of the Moon that triggered volcanic activity on the near side.
- **Mon** - Mountain
- **Montes** – Mountains
- **Palus** – A small plain.
- **Perigee** – Point of lunar orbit closest to Earth.
- **Rill** – Any of several long, narrow meandering valleys or trenches on the moon's surface.
- **Rima** - One of 18 different categories of lunar features recognized in the current system of IAU nomenclature. The IAU defines a rima as a "fissure". The term is used as prefix to the feature name.
- **Rupes** – (aka Scarp), a one-sided feature with the terrain on one side being at a substantially different elevation from that on the other.
- **Terminator** – The line on the Moon or a planet that divides the bright, sunlit part from the part in shadow. It's usually the most exciting and detailed region of the Moon to view through a telescope.
- **Terra** – Latin for land. The higher elevations of the moon.
- **Vallis** – Valley

# Beginners Guide to Small Telescopes – Labs

## Exercise: The Moon

What objects of interest to view on the moon is highly dependent on the phase of the moon when you observe it. This is because features close to the terminator since shadows are more pronounced and highlights features better.

First, we need to determine the phase of the moon for our observation session. A great online resource for this is the NASA website [NASA Dial-A-Moon](#). You can also purchase moon atlases or download an application for exploring the moon. The [Moon Globe HD](#) (iOS, \$1.00) is a great application for this. A [PDF map of the moon](#) showing many features can be downloaded from the USGS website.

Using your references and knowledge of where the terminator will be for the lab, locate a few objects you would like to observed along the terminator line area. Make note of where the targeted item is in reference to one of the easily identified landmarks on the moon.

Reference	Targets	
Area 1 – Mare Serenitatis	A – Aristillus Crater	Diameter = 34 miles. In the middle three clustered peaks rise to a height of about ½ mile.
	B – Mountain Range	See what details you can identify on this rang that divides the Mare Imbrium from the Mare Serenitatis
Area 2 – Rimae Fresnel	A – Apollo 15	Apollo 15 landing site
	B - Fissure	Expected to be caused by tectonic stress
Area 3 - Cassini	A - Crater	Note the various other craters within this crater
Area 4 - Ptolemaeus	A – Line of Craters	Note the line of craters. Was this caused by a series of meteors impact or from cavern cave-ins?
	B – Albatengnius Crater	Examine the crater and center mountain
Area 5 - Hyginus	A - Fissure	Note the craters along the fissure expected to be cave-ins

# Beginners Guide to Small Telescopes – Labs

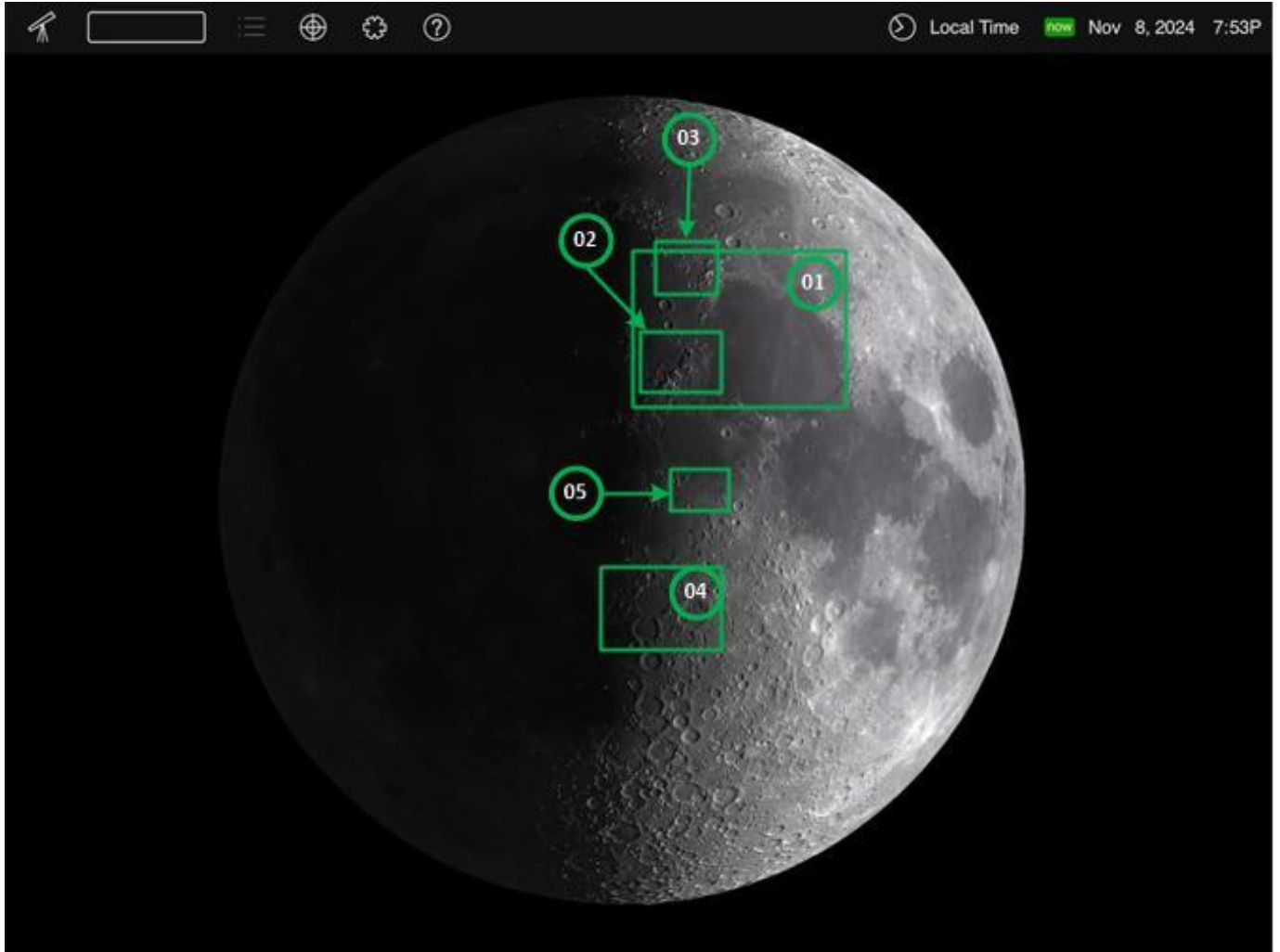

# Beginners Guide to Small Telescopes – Labs

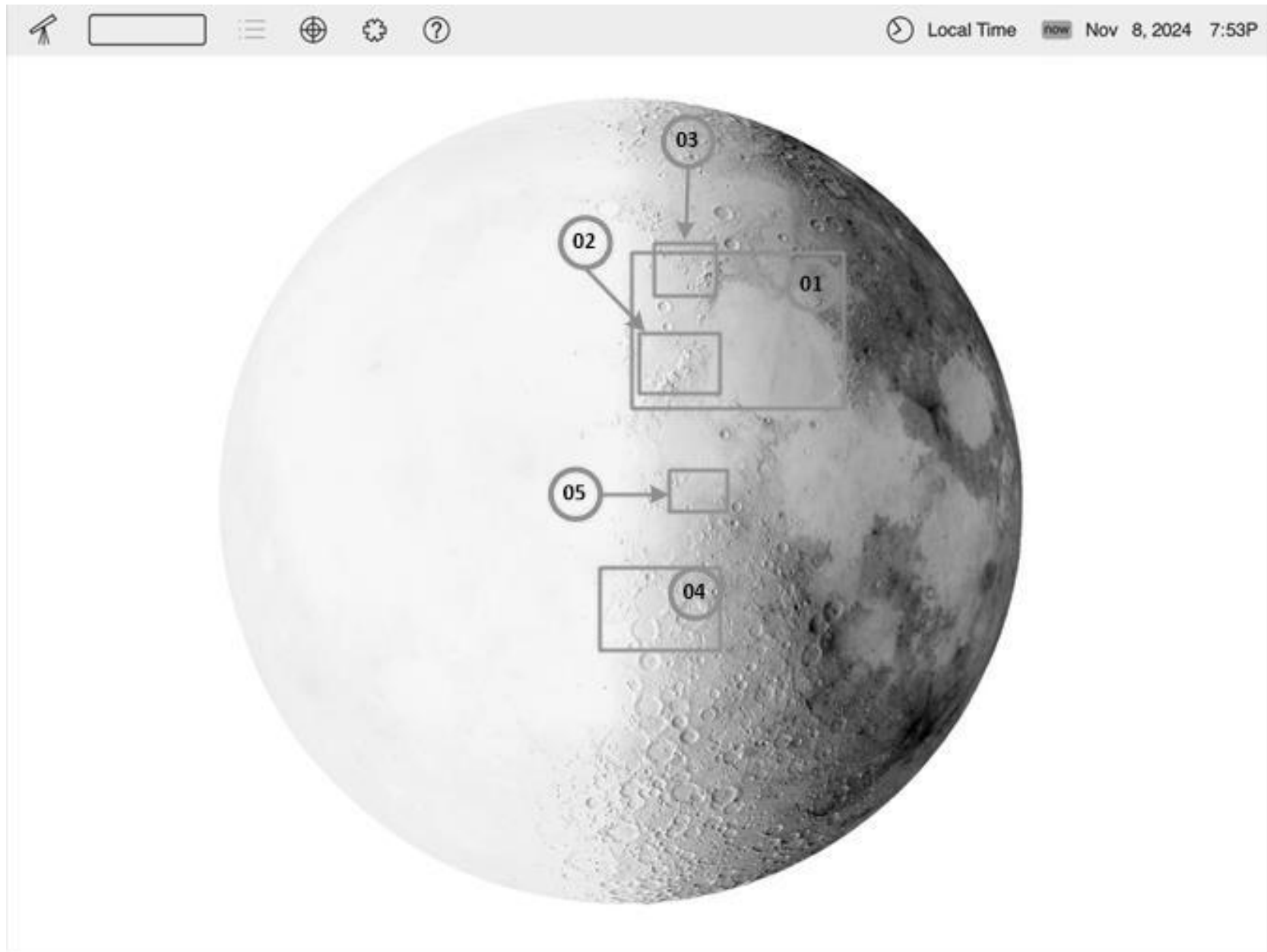



# Beginners Guide to Small Telescopes – Labs



# Beginners Guide to Small Telescopes – Labs



# Beginners Guide to Small Telescopes – Labs

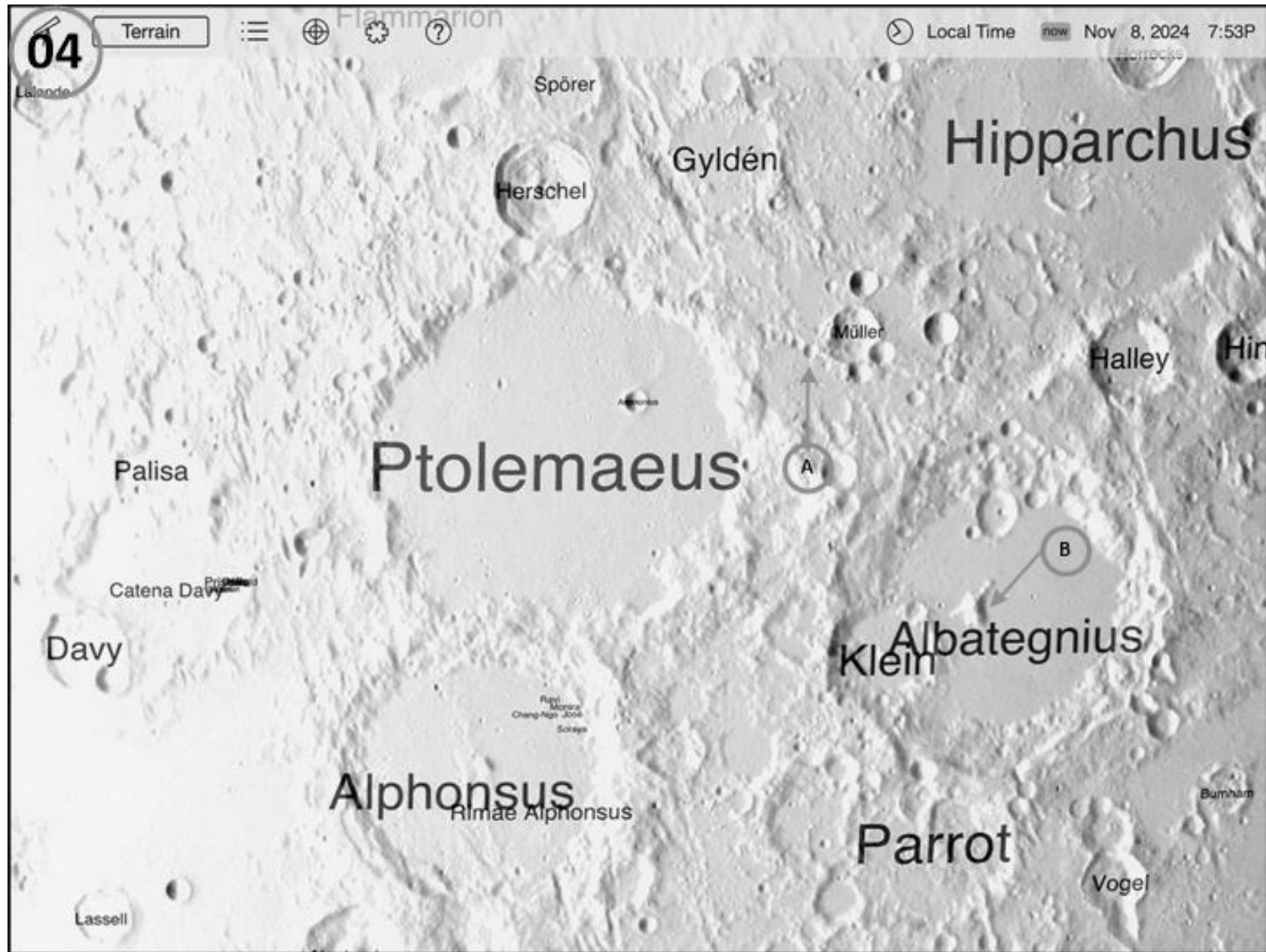

# Beginners Guide to Small Telescopes – Labs



# Beginners Guide to Small Telescopes – Labs

## The Planets

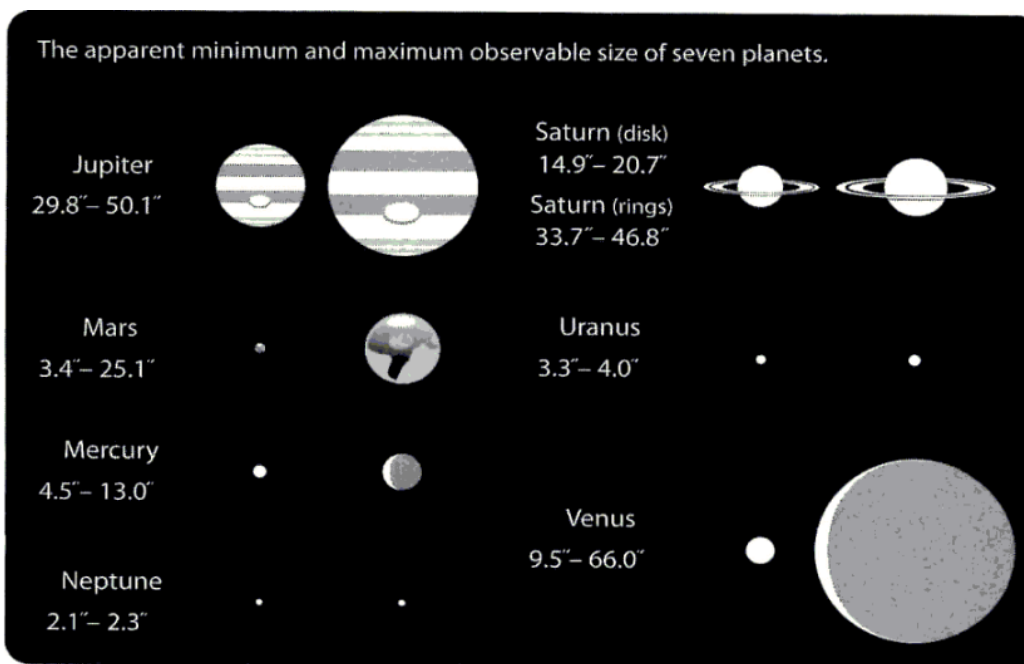



Planetary viewing is particularly dependent upon the seeing conditions. These are fairly bright objects, so higher magnifications will bring some benefit but again, will be limited by how good the seeing is for the night. It usually is best to observe the planet for at a couple of minutes, since you will notice that there will be moments when the view gets particularly good for a split second before the atmosphere muddies the image. It is at these moments when you may catch a glimpse of some of the more subtle features of the planet.

## Beginners Guide to Small Telescopes – Labs

**Venus** | Set = 08:29pm

**Jupiter** | Transit=06:47pm | Set = 01:58am

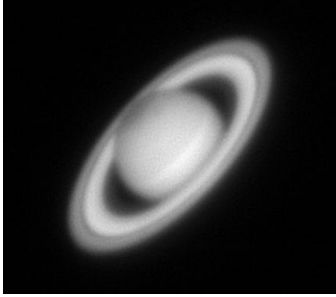
**Uranus** | Transit=03:25pm | Set = 10:21am

Image	Description
	<p><b>Jupiter</b> Usually, the two main bands are visible, and sometimes the great red spot is visible. The four major moons of Jupiter: Io, Europa, Ganymede and Callisto appear as for bright stars in the same orbital plane circling the planet. Occasionally one of the moons transits the planet and if the seeing is particularly good you can see the moon shadow make its way across the surface of the planet (Cool!).</p> <p>Inspect the image here and you can see the two main bands, upper and lower bands, the great red spot and even the shadow of a moon near the pole of the planet.</p>
	<p><b>Saturn</b> Rings of Saturn should be visible. When seeing is particularly good you may be able to spot the <a href="#">Cassini Division</a> in the rings. A number of the moons of Saturn are typically visible, but unlike Jupiter the main moons of Saturn are not in the same orbital plane, so they are harder to distinguish from the background stars.</p> <p><i>The Cassini Division will not be visible for us since the rings are almost edge-on.</i></p> <p>The Cassini Division is clearly visible in this image.</p>
	<p><b>Mars</b> Generally, not much in features can be seen except some lighter and darker regions can be glimpsed. Careful observation may reveal a light region in the top or bottom of the planet. This is a polar cap that grows and shrinks as the Mars Winter progresses.</p> <p>Lighter and darker regions of Mars along with the polar cap is visible in this image.</p>
	<p><b>Venus</b> No features of Venus will be visible. What is interesting to observe is that since Venus is an inner planet, it displays phases like the moon.</p> <p>No features to see, but a phase is clearly visible here.</p>

# Lab 2: Multiple Star Systems

## Goals of The Lab

We will utilize various resources (star wheel, star chart, application, websites) to plan an observation session. We will target constellations to identify, and multiple star systems. We will discuss the importance of determining what sequence to observe objects and introduce the method of star-hopping to locate objects in the sky.

## Resources

East Valley Astronomy Club: [Double Star Program](#)

## Terms

Some key [terms](#) and concepts that are important to know for this lab are:

- **Planisphere (Star Wheel)** – A polar projection of half or more of the celestial sphere on a chart equipped with an adjustable overlay to show the stars visible at a particular time and place.

## Part 1: Using the Planisphere to See What Is Up

Planisphere can help you planning your observations for the night by identify what area of the celestial sphere will be visible.



# Beginners Guide to Small Telescopes – Labs

Another approach of locating constellations of interest is utilizing the Meridian Transits of The Constellations table from the [Astronomy Cheat Sheet](#), page 2 (PDF).

Meridian Transits Of The Constellations														
	Jan	Feb	Mar	Apr	May	Jun	Jul	Aug	Sep	Oct	Nov	Dec		
+80													+80	
+70					UMi				Cep			Cam	+70	
+60			UMa			Dra				Cas			+60	
+50	Lyn			CVn				Cyg	Lac		Per	Aur	+50	
+40			LMi		Boo	CrB	Her	Lyr	Vul	And	Tri		+40	
+30	Gem	Gnc	Leo	Com				Sge	Equ	Peg	Ari	Tau	+30	
+20									Del				+20	
+10	CMi		Sex	Vir		Ser	Oph	Aql			Psc	Ori	+10	
0	Mon												0	
-10													-10	
-20	CMa	Pyx	Hya	Crn	Lib			Cap		Aqr		Cet	-20	
-30											Eri	Lep	-30	
-40	Pup		Ant			Sco	Sgr	Mic	Psa	Scl	Fer	Cae	Col	-40
-50		Vel		Cen	Lup		CrA		Gru	Phe			-50	
	Winter		Spring			Summer			Fall			Winter		

## Part 2: Planning Your Observation Session Walkthrough

Once you have identified what constellations are up, we can identify targets for observation. For this working example we will utilize the online list in the article [Colored Double Stars, Real and Imagined](#) by Sky & Telescope, and additional stars not in this list. The main table in the article is provided on the next page. Note the following columns of interest:

- **Star** – The multiple star system of interest. Notation used for the most part is the Greek alphabet indicating where in the hierarchy of bright stars in the constellation this star is. Note stars that are very well known may just have their name provided.
- **R.A.** – Right Accession of the star
- **Dec.** – Declination of the star
- **Mags** – Visual magnitudes of the stars making up the system. The brightest star is considered the Primary while the next brightest star in the system is considered the secondary star.
- **Sep.** – Separation in Arc Seconds of the stars. Remember one degree is made up of 60 seconds and one second is made up of 60 Arc-Seconds.



# Beginners Guide to Small Telescopes – Labs

proceeds. **One other point** of consideration is that it does take time to locate and observe the objects. After the Sun, Moon and planets, stars tend to be the easiest things to locate in the sky, but this can still be a challenge due to light pollution and how familiar you are with the constellations. This process may take up to 30 minutes for persons without a lot of experience.

Using the Planisphere we can see Perseus (Per), Auriga (Aur), Orion (Ori), Monoceros (Mon), Canis Major (CMi), Canis Major (CMa), Gemini (Gem), Cancer (Cnc), Hydra (Hya), Sextans (Sex), Leo (Leo), Leo Minor (LMi), Ursa Major (UMa), Crater (Crt) are some of the many constellations that will be up in the sky in the early evening.

### MINIMUM SEPARATION FOR AN APERTURE

$\Delta m$  is the difference in magnitude between the primary and secondary stars. The estimated minimum separation for the different apertures is in arcseconds. These estimates are useful only when the primary star is magnitude 6.5 or brighter.

Magnitude difference	60-mm	100-mm	150-mm	200-mm	250-mm
$\Delta m$ 0.0	2.0"	1.2"	0.8"	0.6"	0.5"
$\Delta m$ 0.5	2.0"	1.2"	0.8"	0.6"	0.5"
$\Delta m$ 1.0	2.2"	1.3"	0.9"	0.8"	0.6"
$\Delta m$ 1.5	2.5"	1.4"	1.0"	0.9"	0.7"
$\Delta m$ 2.0	3.2"	1.9"	1.2"	1.1"	0.9"
$\Delta m$ 2.5	3.5"	2.0"	1.4"	1.3"	1.1"
$\Delta m$ 3.0	3.7"	2.3"	1.6"	1.5"	1.3"
$\Delta m$ 3.5	4.4"	2.4"	1.8"	1.6"	1.5"
$\Delta m$ 4.0	4.5"	2.6"	2.0"	1.9"	1.6"

## STAR MAGNITUDE

**SIRIUS IS BRIGHTEST MAG. -1.6**

**STAR MAGNITUDE SCALE**

**RELATIVE BRIGHTNESS (FIRST MAGNITUDE STAR RATED 100)**

**NAKED EYE LIMIT - CITY**

**COUNTRY**

**USE OF TABLE**

**FIND DIFFERENCE BETWEEN A 4<sup>th</sup> MAG. STAR AND A STAR OF 9<sup>th</sup> MAG. SOLUTION: 9 - 4 = 5 MAGS. DIFFERENCE FROM TABLE: 5 MAGS. DIFF. = 100 THEREFORE: 9<sup>th</sup> MAG. IS 100 TIMES FAINTER**

**EACH MAGNITUDE STEP IS A DIFFERENCE IN BRIGHTNESS OF 2.5 TIMES**

**LIMIT FOR 200" (Photographic Mix)**

**LIMIT FOR 200"**

**LIMIT FOR 3" TELESCOPE**

**LIMIT FOR 6"**

**LIMIT FOR 12"**

**BRIGHTNESS DIFFERENCE BY MAGNITUDES**

ONE MAGNITUDE = 2.5 TIMES	SIX MAGNITUDES = 251 TIMES
TWO MAGNITUDES = 6.3 TIMES	SEVEN MAGNITUDES = 631 TIMES
THREE MAGNITUDES = 15.8 TIMES	EIGHT MAGNITUDES = 1585 TIMES
FOUR MAGNITUDES = 39.8 TIMES	NINE MAGNITUDES = 3981 TIMES
FIVE MAGNITUDES = 100 TIMES	TEN MAGNITUDES = 10000 TIMES

## Beginners Guide to Small Telescopes – Labs

Reviewing the Double Star List, we see the following Targets that are in these constellations. These are listed in order of increasing R.A. (Going from West to East).

Star	Constellation	RA	DEC	Mag	Sep	Comments
η Per	Perseus (Per)	02h 51m	+55° 54'	3.8   8.5	28"	SAO-023655
Polaris	Ursa Minor (Umi)	03h 05m	+89° 22'	2.0   9.1	18"	SAO-00308 (not in list)
γ Lep	Lepus (Lep)	05h 44m	-22° 27'	3.6   6.3	97"	SAO-170759
ρ Ori	Orion (Ori)	05h 13m	+02° 52'	4.6   8.5	7"	SAO-112528
14 Aur	Auriga (Aur)	05h 15m	+32° 41'	5.0   7.4	15"	SAO-057799
ε Gem	Gemini (Gem)	06h 56m	+13° 08'	4.7   7.8	7.4"	SAO-096265
Castor	Gemini (Gem)	07h 36m	+31° 50'	1.6   3.0	5.2"	SAO-060198
HD 56578	Canis Major (CMa)	07h 17m	-23° 21'	5.9   5.0	27"	* Yellow   Blue SAO-173353
h3945 CMa	Canis Major (CMa)	07h 17m	-23° 19'	5.0   5.8	27"	SAO-173349
ι Cnc	Cancer (Cnc)	08h 47m	+28° 46'	4.0   6.6	31"	SAO-080416
Algieba	Leo (Leo)	10h 21m	+19° 41'	2.2   3.6	4.8"	SAO-081298
V Hya	Hydra (Hya)	10h 53m	-21° 23'	7.6   11	45"	* Blood RED primary!!! SAO-179278
24 Com	Comae Berenices (Com)	12h 35m	+18° 23'	5.1   6.3	20"	SAO-100159
Mizar, Alcor	Ursae Majoris (UMa)	13h 25m	+54° 47'	2.1   4.0	<b>11.8'</b>	SAO-028737
ξ Boo	Bootes (Boo)	14h 51m	+19° 06'	4.8   7.0	6"	SAO-101250

Next, we would narrow down the list based on our instrument limitations. Below are a few examples of the thinking process I will go through when evaluation what targets to view.

Star	Comments
Polaris	Easily located (North Star) at the end of the little dipper. Separation is good at 18" however the magnitude difference of 7 meaning "A" is about 630 times brighter than "B" in this system, so close attention must be paid to see the secondary star.
η Per	Another bright star (3.8) located in the constellation Perseus, also reaching high elevation when highest in the sky (+55°). This star should be pretty easy to resolve with a separation of 28". However, there is a 4.7 magnitude difference between these stars, so the secondary star will be in the neighborhood of 50x dimmer than the primary, so it may be a bit of a challenge to spot.
ρ Ori	Fairly dim star at 4.6 magnitude this may be challenging to locate. With a difference in magnitude of about 4, "A" will be about 40x brighter than "B", with a separation of 7" this should still be resolvable with most telescopes.

## Beginners Guide to Small Telescopes – Labs

Star	Comments
14 Aur	The number 14 here indicates we have passed the Greek alphabet and reverted to ordering the star brightness in the constellation by sequential numbers, so this is a minor star in the constellation. We see the primary is a magnitude 5.0 star, so probably not even visible to the naked eye in the city. If we really want to view this double, we will probably have to utilize the RA and DEC coordinates to guide us to the star with a technique not yet covered in this class. This star is going to likely require a technique to be covered in the future for locating objects in the night sky. While this pair is fairly close in magnitude (2.4) they are quite close together, so may require a higher magnification eyepiece to resolve them.
$\gamma$ Lep	Should be bright enough to locate in the sky, with magnitude difference of 2.7 and separation of 97'' this should be easily resolved in any telescope or binocular.
h3945 CMa	A dim star with almost identical magnitudes this wide pair should be easily separated once found, but at magnitude 5.0 this star is not visible to the naked eye in the city.

Finally, we need to determine what order we want to observe the stars we have identified. This will be accomplished by examining the Right Ascension (RA) values for each star. Since stars rise in the East and set in the West, we need to target the West most stars first and work our way East. The RA coordinate system is measured in Hours, Minutes and Seconds the same as a clock. Values of RA increase as we travel from West to East across the sky starting at 00 hours, 00 minutes and 00 seconds and progressing to 23 hours 59 minutes and 59 seconds, then they start back up at 00 hours, 00 minutes and 00 seconds as we continue. Using a Planisphere, sky atlas, or application, we can see that the Perseus constellation is the west most constellations in our list at this date (April 3<sup>rd</sup>) and time (8pm).

So  $\delta$  Cep (22h 29m) will be our first target followed by  $\eta$  Cas (00h 49m),  $\eta$  Per (02h 51m) and finally 14 Aur (05h 15m) will be our last target. The resulting viewing order is now

Order	Star	Constellation	RA	DEC	Mag	Sep
01	$\eta$ Per	Perseus (Per)	02h 51m	+55° 54'	3.8   8.5	28''
02	Polaris	Ursa Minor (Umi)	03h 05m	+89° 22'	2.0   9.1	18''
03	$\gamma$ Lep	Lepus (Lep)	05h 44m	-22° 27'	3.6   6.3	97''
04	$\rho$ Ori	Orion (Ori)	05h 13m	+02° 52'	4.6   8.5	7''

This all seems a bit complicated for a hobby! In practice the typical amateur astronomer will go out, see what constellations are well positioned in the sky, go to the list and pick some stars in those constellations for viewing. Next, they identify the physical location of the star in the constellation using a phone application, or start atlas and locate it in the sky. Finally, they aim their telescope at the star and examine the star system. If they are having issues locating the star system, or resolving the pair, they consult the table to try to determine the cause. Issues such as pairs with a small separation (requiring higher magnification) to resolve the stars, or the possibility that the primary is so bright it is hiding the secondary, or a combination of the two are usually answered by inspecting the provided data from the table. Indeed, part of the joy of viewing multiple star systems is not knowing what to expect when you take a look in the eyepiece. The details on the system are used for troubleshooting and verifying that you have the correct system being described.

# Beginners Guide to Small Telescopes – Labs

## Exercise

In the next viewing session, we will be observing some double star systems. In the exercise below you will determine what stars you will be your targets for the evening. A key technique you will utilize when looking for the target star system is a technique known as Star Hopping. Please take the time to read this article so you are aware of the technique: [Star Hopping 101: The Beginners Guide to Star Hopping](#).

Use a [Meridian Transits of Constellations](#) table and the [double star](#) table listed earlier in this chapter to select three multiple star systems for observation following the process outlined above. A double system  $\alpha$  Ursae Minors (UMi) (aka Polaris; the North Star) in the Small Dipper will be provided as an example since it is always visible at our latitude, is a nice double, and extremely easy to locate since it is the North Star; probably the most important star for most astronomers since it is use for setting up many telescopes (to be covered in later labs).

## Beginners Guide to Small Telescopes – Labs

1. Identify some well positioned constellations using the planisphere for the date and time of your next observation session (next lab date/time).

Date	Time	Constellation	Abbreviation	Comments
TBD	TBD	Ursa Minor	UMi	Parts of this constellation are always up

2. Using the [22 Interesting Multiple Star Systems](#) table above list possible target star systems for your observation session.

Star	Constellation	RA	DEC	Mag	Sep	Comments
$\alpha$ Umi	Ursa Minor (Little Dipper)	03h 00m	+89° 21'	2.0, 9.1	18.4"	Difference of 7.9 magnitude between primary and secondary, fairly close together, a good challenge for small scopes.

3. Identify best 4 target stars for observation

Item	Star	Comments
01	<b>Polaris</b> ( $\alpha$ Umi)	Polaris, Most important star in the sky for most astronomers. Critical you can locate this star in the night sky. Difference of 7.9 magnitude between primary and secondary, fairly close together, a good challenge for small scopes.
02		
03		
04		

## Beginners Guide to Small Telescopes – Labs

4. Order stars for observation, targeting stars furthest to the west as first target moving east to the last targeting being the most easterly star. (With the exception of Polaris, we will make this our first target).

Order	Star	Constellation	RA	DEC	Mag	Sep
01	Polaris	Ursa Minor (Little Dipper)	03h 00m	+89° 21'	2.0, 9.1	18.4"
02						
03						
04						

# Beginners Guide to Small Telescopes – Labs

## Observation Session: Multiple Star Systems

Locate stars and write down your observations on each of the star systems

Name: \_\_\_\_\_

Date: \_\_\_\_\_

Order	Star	Constellation	Time	Comments
01	$\alpha$ Umi (Polaris)	Ursa Minor (Little Dipper)		
02				
03				
04				

## Lab 3: Telescope Types and Mounts

---

### Goals of the Lab

We review in detail the steps involved with setting up your telescope including:

- Mount Rough Alignment
- Leveling the Telescope Mount
- Balancing the Telescope
- Align the telescope to the North Celestial Pole (NCP)
- Finderscope Alignment

After setting up your telescope you will view some deep sky objects.

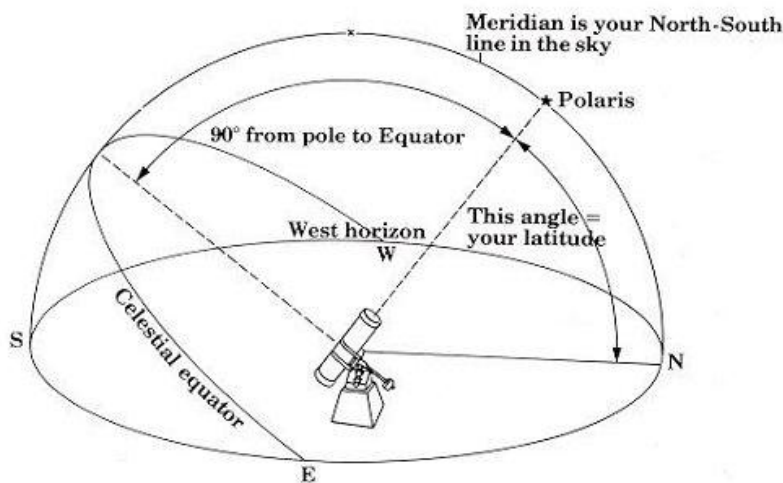

### Terms

Some key [terms](#) and concepts that are important to know for this lab are:

- **Altitude** – the vertical position of a star or other astronomical object in the sky measured from the horizon.
- **Azimuth** – the horizontal position of a star or other astronomical object in the sky measured from compass north.
- **Clock-drive** – a motor used with an equatorial mount to track objects. When observing the sky with a properly aligned clock-drive mount, it compensates for the Earth's rotation, keeping celestial objects centered in the field of view.
- **Counterweight** – a weight placed on the counterweight shaft to balance out the weight of the optical tube and accessories on the other side of the right ascension axis.
- **Declination (Dec)** - The celestial equivalent of latitude, denoting how far (in degrees) an object in the sky lies north or south of the celestial equator.
- **GoTo Alignment** – the process of synching up your computerized telescope with the sky in order to use the GoTo feature to locate celestial targets.
- **Latitude** – You need to know your local Latitude (Phoenix Metro area is 33°), it is utilized in Equatorial mounts to set angle of the mount to the vertical position of the North Celestial Pole.
- **Meridian** – The imaginary north-south line that passes directly overhead (through the zenith).

# Beginners Guide to Small Telescopes – Labs

- **Polar alignment** – the process of accurately aligning your equatorial mount’s polar axis with the celestial pole.
- **Polar axis** – the axis of rotation of an equatorial mount that is parallel to the earth's axis of rotation.
- **Polaris** – AKA the North Star. It is vital you know how to locate this star since it is so close to the North Celestial Pole (NCP).
- **Right Ascension (R.A.)** - The celestial equivalent of longitude, denoting how an object lies east of the Sun’s location during the March equinox.
- **Zenith** – The point in the sky that’s directly overhead.

## Part 1: Telescope Mount Alignment Procedure

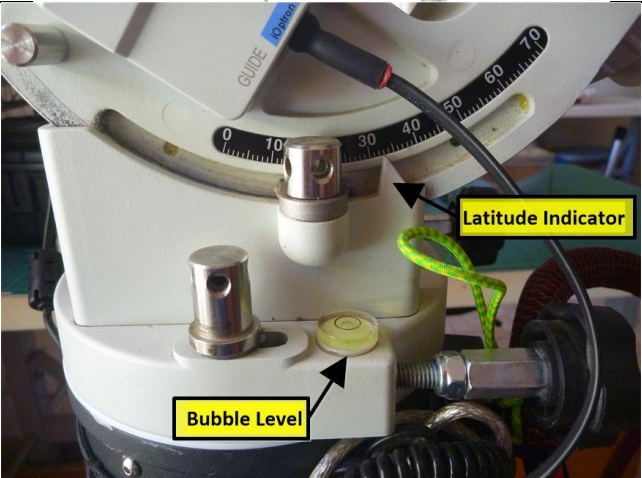

The details of the alignment process a telescope mount varies from telescope to telescope. Generally, a modest size telescope on an Alt/Az or GoTo mount may only need to be leveled before proceeding. Equatorial mounts are a bit more work to setup. You may want to view the video [How To Use an EQ Telescope as a quick introduction](#) as an overview of the material that will be covered next.

Step	Image
<p><b>Step 1: Mount Rough Alignment (Equatorial)</b></p> <p>If you have an equatorial mount, place the tripod so the Polar Axis of the mount is pointing North, if it is dark enough, point it towards the North Star. Check the Latitude setting on the mount to ensure it matches the Latitude for your location (Phoenix Metro Area is 33° N).</p> <p><i>Note: Photo in next step identifies Latitude scale and indicator on a typical Equatorial mount.</i></p>	
<p><b>Step 2: Leveling the Telescope Mount</b></p> <p>Most astronomical mounts have levels built into the tripod or mount, if not you will need to <a href="#">supply your own</a>. Use the bubble level to ensure the mount is level. Adjust the height of the tripod legs to accomplish this.</p>	

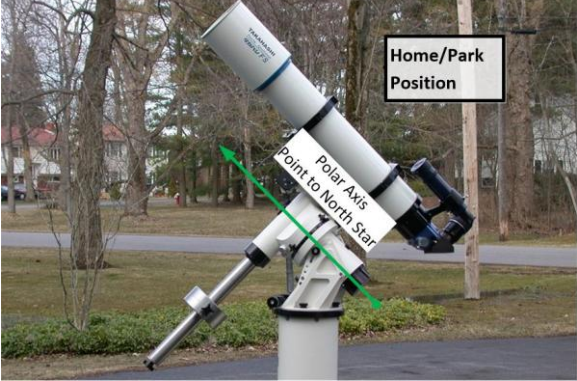
# Beginners Guide to Small Telescopes – Labs

Step	Image
<p data-bbox="126 239 789 527"><b>Step 3: Balance the Telescope (Equatorial)</b> While performing this process it is a good idea to keep one hand on the telescope Tube so you can catch it if it makes a sudden unexpected move. I would recommend having someone show you this procedure or watch a video like this one <a href="#">Balancing an Equatorial Mount</a> before attempting this on your own.</p> <ol data-bbox="126 569 789 1367" style="list-style-type: none"><li>1. Balance the RA Axis - Make sure to counter weight is at the end counterweight shaft and locked into position. Loosen the RA lock lever and rotate the telescope and shaft so they are horizontal. Slowly move the counterweight towards the telescope until the counterweight exactly balances the telescope. Lock the counter weight into place.</li><li>2. Balance the DEC Axis – With the RA axis still in the horizontal position move the DEC axis until the OTA is horizontal. Loosen the DEC axis and determine if the OTA needs to be shifted forward or back to ensure the OTA stays in place if the DEC axis is fully released.</li><li>3. If you position both the RA and DEC axis in the horizontal positions and fully release both axis locks and the OTA does not move you know your telescope is balanced.</li><li>4. Once balance of both axis has been achieved, you can now move your telescope back in the home/park position (RA axis Vertical with the OTA pointing to the NCP). Lock both axis.</li></ol>	<p data-bbox="1143 275 1187 302">1-3</p>  <p data-bbox="1154 821 1175 848">4</p> 

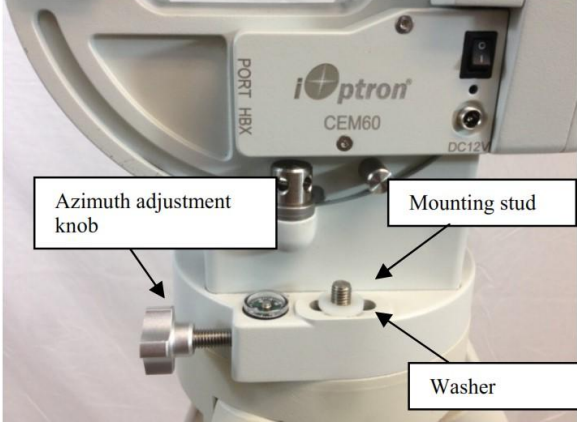
# Beginners Guide to Small Telescopes – Labs

Step	Image
<p data-bbox="126 237 581 273"><b>Step 4: Re-Alignment (Equatorial)</b></p> <p data-bbox="126 310 781 525">Now that the telescope is roughly aligned and balanced, you can proceed to make more accurate adjustments to point the telescope at the North Star for alignment good enough for visual observing by adjusting the Latitude and Azimuth knobs as needed.</p> <p data-bbox="126 569 776 783">Some telescopes may come with a dedicated polar alignment scope built in the base of the mount that has markings to allow for more accurate adjustments that may be needed for astrophotography; this will not be covered in this class.</p>	<p data-bbox="1029 275 1300 310"><b>Azimuth Adjustment</b></p>  <p data-bbox="943 499 1105 558">Azimuth adjustment knob</p> <p data-bbox="1279 499 1414 527">Mounting stud</p> <p data-bbox="1300 684 1373 711">Washer</p> <p data-bbox="951 772 1377 808"><b>Polar Alignment Scope in Mount</b></p>  <p data-bbox="1068 1136 1295 1163">Polar Alignment Scope</p>

# Beginners Guide to Small Telescopes – Labs



## Part 2: Finderscope Alignment Procedure

The first time you attempt to align your finderscope with the main telescope will likely be the most challenging simply because the finderscope will probably be completely out of alignment and you will not be able to use it to trace your targeted star or other object in the main scope easily. It is recommended that the first attempt of alignment be performed during the day so that you can point the main scope at a distant terrestrial object and then make adjustments to the finderscope to roughly align them since it will be much easier to determine what the telescope it pointed at during the day.

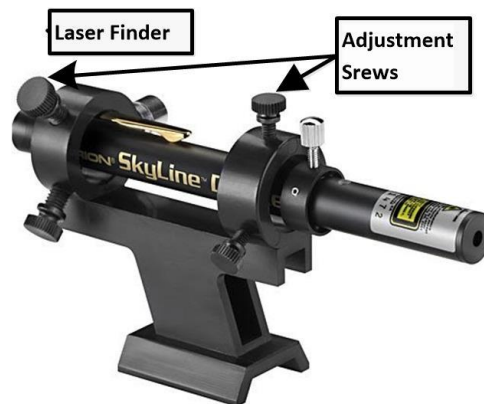
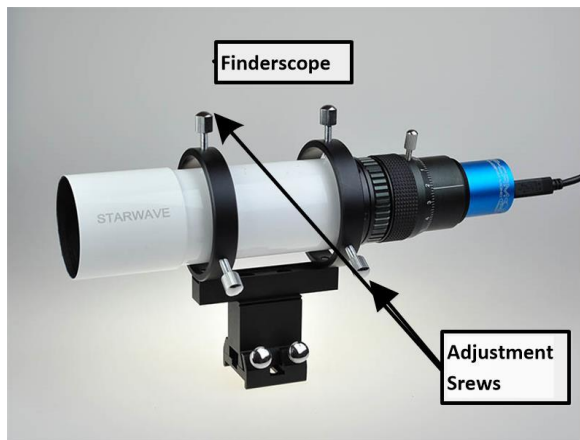

### Common Types of Finder Scopes and location of Adjustment screws



## Beginners Guide to Small Telescopes – Labs

Step	Image
<p><b>Step 1: Know Your Finderscope</b></p> <p>There are four types of finders commonly used (images above). Determine what one you have and locate the knobs or screws used to make alignment adjustments.</p>	<p>(See Above)</p>
<p><b>Step 2: Select Your Target</b></p> <p>There are two types of targets to choose from a <b>terrestrial</b> one such as a tree, chimney, light post etc. or <b>celestial</b> such as the moon, planet or bright star. If you are using a terrestrial target, you will <u>not</u> need to worry about telescope mount alignment. However, if you select a celestial target you will need to first preform the telescope mount alignment since your target will be moving across the sky as you perform the finderscope alignment.</p>	
<p><b>Step 3: Prepare Equipment</b></p> <p>As mentioned earlier if you are attempting alignment on a celestial object such as the Moon or a bright Star you will need to first perform a Telescope Mount Alignment.</p> <p>Eyepiece – Place your lowest power eyepiece in the main telescope. This will ensure you have as wide as a field of view possible.</p> <p>Turn On Equipment – Telrad, Red Dot and Laser finders will need to be turned on. Conventional finder scopes may also have an illuminated reticle with crosshairs that needs to be turned on.</p>	<p><b>Illuminated Reticle Eyepiece</b></p> 

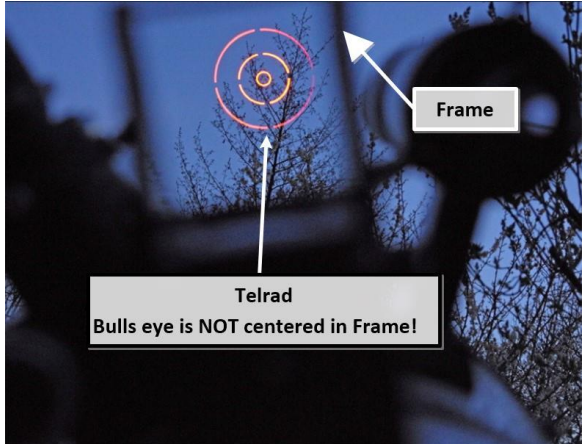
# Beginners Guide to Small Telescopes – Labs

Step	Image
<p><b>Step 4: Rough Alignment</b></p> <p>Center the target object in the main telescope.</p> <p><i>NOTE: For Telrad, Red Dot and lesser extent Laser finders the position of your head relative to the frame of the finder is critical. Make sure the Red Dot or Bulls eye is centered in the <u>frame</u> at all times before making adjustments. If it is not centered re-position <u>your head</u> to make sure it is. The image to the right shows the person needs to move to the left to make sure the bullseye is centered in the frame before making adjustments to the finder. As you make adjustments you will likely need to slightly reposition yourself to ensure the bulls eye/red dot remains in the center of the frame.</i></p> <p>Make adjustments to the finder alignment screws or knobs to center bullseye on the target object. Make sure the red dot is centered in the frame before proceeding to make adjustments to center the bullseye/red dot on the target object. We want the bullseye centered in the frame and the object centered in the bulls eye.</p> <p>Go back to the Main scope and re-center the target (it has likely moved) and move back to the finder to re-center the target in the finder.</p> <p>Once you are satisfied the main telescope and finder are both centered on the target you have completed the rough alignment. Move to the next step.</p>	<p style="text-align: center;"><b>Image</b></p> <p style="text-align: center;"><b>Telrad Finder</b></p>  <p style="text-align: center;"><b>Laser Finder</b></p> 
<p><b>Step 5: Fine Tuning</b></p> <p>Having a finderscope in very close agreement with the main telescope is critical for ensuring your observation session goes smoothly. Replace you low power eyepiece with a higher power eyepiece and re-center the target in the main telescope. Proceed to fine-tune the finderscope to ensure it matches the main scope.</p> <p>Note: for Telrad and Red Dot finders the further back you are from the finder, the more accurate you can make alignment to match the main telescope.</p> <p>Once you are comfortable both scopes are in alignment, you are done.</p>	<p style="text-align: center;"><b>Red Dot Finder</b></p> 

# Beginners Guide to Small Telescopes – Labs

## Exercise: Planning Your Observation Session

This week we will re-enforce the process of how to plan your observation session. We expand our search to other deep sky objects including Galaxies, Bright Nebula, Globular Clusters, Open Clusters and Planetary Nebula. We also introduce the concept of using Setting Circles (for Equatorial mounts). Please review the article [Using Setting Circles on Your Telescope To Find Objects](#) before the class.

This time instead of using a Planisphere to determine the constellations that are well positioned, we will utilize the table on the next page ([Meridian Transits of The Constellations](#)). An example of how this may be used we will identify constellations ideally placed for the month of July (**Jul**) this would include (in order of increasing Declination from -30 up) Sagittarius (**Sgr**), Capricornus (**Cap**), Scutum (**Sct**), Aquila (**Aql**), Delphinus (**Del**), Sagitta (**Sge**), Vulpecula (**Vul**), Cygnus (**Cyg**), Lyn (**Lyn**), Lyra (**Lyr**).

Moving on to the next table ([25 Potential Objects for Small Telescopes](#)) we will locate the identified constellations in the **Const** column and list the targets that are located in these constellations. The items in this list are listed in order of increasing R.A. so they are already ordered in the preferred observation order.

Const	Object Type	ID	R. A.	DEC	Mag	Size	Description/Close by Star
Sgr	BN	<b>M-8</b>	18h 05m	-24° 23'	6.0	90' x 40'	Sagittarius: Nunki (2.1)
Sgr	BN	<b>M-17</b>	18h 22m	-16° 10'	6.0	46' x 37'	Sagittarius: Nunki (2.1)
Sgr	Gb	<b>M-22</b>	18h 38m	-23° 53'	5.1	32'	Sagittarius: Nunki (2.1)
Lyr	Ms	<b>ε Lyr</b>	18h 45m	+39° 42'	5.0	2.2"	(Summer Triangle) Lyra: Vega(0.0)
Lyr	Pn	<b>M-57</b>	18h 54m	+33° 03'	8.8	1.4' x 1.1'	(Summer Triangle) Lyra: Vega(0.0)
Cyg	Ms	<b>Abireo</b>	19h 32m	+28° 00'	3.1	34.6"	(Summer Triangle) Lyra: Vega(0.0)
Vul	Pn	<b>M-27</b>	20h 01m	+22° 47'	7.1	8.0' x 5.7'	(Summer Triangle) Lyra: Vega(0.0)

## Exercise

Using the tables supplied on the next page plan your next observation session.

**Constellations well placed:**

**Identify objects for observation:**

Const	Object Type	ID	R. A.	DEC	Mag	Size	Description/ Close By Star

# Beginners Guide to Small Telescopes – Labs

Meridian Transits Of The Constellations														
DEC	Jan	Feb	Mar	Apr	May	Jun	Jul	Aug	Sep	Oct	Nov	Dec	DEC	
-50		Vel		Cen		Nor	Tel		Gru	Phe				-50
-40				CVn		Sco	CrA	Mic				Cae	Col	-40
-30		Pyx	Ant			Pup	Sgr		PsA	Scl	For	Eri		-30
-20	CMA							Cap					Lep	-20
-10	CMi	Hya		Crt	Crv	Lup	Lib							-10
0	Mon	Sex			Vir	Ser	Oph	Sct	Aql				Ori	0
+10								Del	Equ					+10
+20	Gem	Cnc	Leo		Com			Sge	Vul	Peg		Ari	Tau	+20
+30			LMi			Boo	CrB	Her				Tri		+30
+40							Lyn	Cyg	Lyr				Aur	+40
+50			UMa							Lac			Per	+50
+60											Cep			+60
+70						Dra					Cas		Cam	+70
	Jan	Feb	Mar	Apr	May	Jun	Jul	Aug	Sep	Oct	Nov	Dec		

## Potential Objects for Small Telescopes

Const	Object Type	ID	R. A.	DEC	Mag	Size	Description
Aqr	Gb	M-2	21h 35'	-00° 43'	6.5	16'	Globular in Aquarius
Peg	Gb	M-15	21h 31m	+12° 16'	6.0	18'	Densely packed core
Vul	Pn	<b>M-27</b>	20h 01m	+22° 47'	7.1	8.0' x 5.7'	Dumbbell – Brightest PN in sky
Sgr	Gb	M-55	19h 41m	-30° 55'	6.3	19'	Globular in Sagittarius
Cyg	Ms	<b>Abireo</b>	19h 32m	+28° 00'	3.1	34.6"	Great! - Yellow(3.1) and Blue(4.7)
Lyr	Pn	M-57	18h 54m	+33° 03'	8.8	1.4' x 1.1'	Ring Nebula planetary nebula
Lyr	Ms	<b>ε Lyr</b>	18h 45m	+39° 42'	5.0	2.2"	A Double Double star system
Sgr	Gb	<b>M-22</b>	18h 38m	-23° 53'	5.1	32'	Third brightest Globular in north sky
Sgr	BN	<b>M-17</b>	18h 22m	-16° 10'	6.0	46' x 37'	Swan Nebula
Sgr	BN	<b>M-8</b>	18h 05m	-24° 23'	6.0	90' x 40'	Lagoon Nebula with open cluster
Sco	Oc	M-7	17h 55m	-34° 47'	3.3	80'	Large, brilliant open cluster
Her	Gb	M-92	17h 18m	+43° 07'	6.4	14'	Bright globular
Her	Gb	<b>M-13</b>	16h 42m	+36° 25'	5.8	20'	Best Globular Cluster in sky
Sco	Gb	M-4	16h 25m	-26° 35'	5.6	36'	Large Globular Cluster in Scorpius
Ser	G	<b>M-5</b>	15h 20m	+02° 00'	5.6	23'	Fine Globular
CVn	Gb	<b>M-3</b>	13h 43m	+28° 16'	6.2	18'	A bright Globular
UMa	Sp	M-51	13h 31m	+47° 05'	7.9	14' x 12'	Face-On Spiral galaxy w companion
UMa	Ms	<b>Mizar</b>	13h 25m	+54° 48'	2.2	0.8"	ζ UMa with 2.2 & 3.9 mag stars
Vir	Sp	M-104	12h 41m	-11° 45'	8.1	8' x 5'	Sombrero Galaxy – Edge on
Leo	Sp	M-65, et. el.	11h 20m	+12° 58'	N/A	N/A	The Leo Trio three galaxies
UMa	Pn	M-97	11h 16m	+54° 54'	9.8	3' x 3'	Planetary Nebula Owl Nebula
UMa	Sp	M-81, M-82	09h 57m	+68° 57'	6.8	22' x 11'	Two galaxies close to each other
Com	Gb	M-53	09h 30m	+18° 03'	7.6	13'	Globular
Her	Ms	Rigel	07h 53m	-08° 11'	0.3	9.4"	Double Star with 0.3 & 6.8 mag
Pup	Oc, Pn	M-46	07h 43m	-14° 51'	6.1	20'	Open cluster with sm Planetary Neb
CMA	Oc	M-41	06h 47m	-20° 46'	4.5	39'	Bright Open cluster
Mon	Oc, BN	NGC-2244	06h 33m	+04° 55'	4.8	29'	The Rosette Nebula
Aur	Oc	M-37	05h 54m	+32° 33'	6.0	14'	Bright Open Cluster
Oph	Gb	M-10	05h 46m	-04° 08'	6.6	20'	Good Globular
Aur	Oc	M-76	05h 38m	+34° 09'	6.0	10'	The Pinwheel Cluster
Ori	BN	<b>M-42</b>	05h 37m	-05° 26'	4.0	85' x 60'	The Great Orion Nebula

## Beginners Guide to Small Telescopes – Labs

Const	Object Type	ID	R. A.	DEC	Mag	Size	Description
Tau	Pn	M-1	05h 36m	+22° 02'	8.4	6' x 4'	The Crab Nebula
Lup	GC	M-79	05h 25m	-24° 30'	7.7	9.6'	Small Globular
UMi	Ms	<b>Polaris</b>	03h 00m	+89° 22'	2.0	18.4"	Nice double with dim companion
Tau	Oc	M-45	03h 48m	+24° 11'	1.5	120'	The Pleiades
Cas	Ms	ι Cas	02h 31m	+67° 30'	4.6	2.6"	Fine Quadruple System 4.6 & 6.9
Per	Oc	NGC-869, NGC-884	02h 21m	+57° 13'	5.3	60' x 30'	Double Open Cluster
And	Ms	<b>γ And</b>	02h 05m	+42° 26'	2.2	9.4"	Double Star with 2.2 & 5.0 mag
Tri	Sp	<b>M-33</b>	01h 35m	+30° 47'	5.8	62' x 37'	The Triangulum Galaxy
And	Sp	<b>M-31</b>	00h 44m	+41° 43'	3.3	178' x 70'	Andromeda Galaxy best galaxy

BN = Bright Nebula	Ms = Multiple Star System	Pn = Planetary Nebula
Gb = Globular Cluster	Oc = Open Cluster	Sp = Spiral Galaxy

# Lab 4: Collimation and Techniques for Finding Objects

---

## Goals of the Lab

The focus of this weeks lab will be Telescope maintenance. The first rule is to try to take care of your telescope to minimize any required maintenance. Here are some things to keep in mind:

- **Treat with Care** - Try to avoid jostling your telescope since this will cause the optics to become misaligned requiring you collimate your telescope.
- **Don't Touch the Optics** – Eyepieces and telescope optics will generally have special coatings that can easily be damaged. Cleaning the optics can sometimes do more damage than help.
- **Brush and Bulb** – Do use a brush a bulb to blow and wipe dust off easy to access optics after every session. For SCT and Refractors this includes the lens at the front of the telescope. Also store your telescope so that dust will not land on the primary mirror or lens.
- **Cover and Care** – When not using the telescope ensure the cover for the main optics is put into place. Ideally you should store the telescope in a climate controlled environment since large changes in temperature can cause the optics to become misaligned over time.

## Terms

Some key [terms](#) and concepts that are important to know for this lab are:

- **Collimation** – The process of aligning all components in a telescope to bring light to its best focus.
  - **Mechanical Collimation** – Alignment of the physical components in your telescope. It is the process of moving the physical components of an optical system to their proper positions before Optical Collimation is performed. Generally, most telescopes are already mechanically collimated.
  - **Optical Collimation** - Aligns a telescope's optical surfaces to bring the image to the correct orientation in the focal plane.

## Checking Collimation

To ensure you are getting the best image possible from your telescope it is important to regularly check your telescope collimation. Checking collimation is performed to ensure optical components of your system are first properly placed relative to each other (**Mechanical Collimation**). For instance, to check to see if your primary mirror is in the center of the tube, the secondary mirror is in the center of the tube, etc. This is a process that can be performed in doors and during the day. **Optical Collimation** is the process of verifying each of the components of the system oriented appropriately to guide gathered light to the appropriate positions. This is the process of adjusting tilt and angle of reflection of the various components in the system (ie Primary and secondary mirrors). The distinction between Mechanical and Optical Collimation is usually not made, and the entire process is simply referred to as **Collimation**.

The Collimation process is dependent on the Optical Tube Assembly (OTA) design. Generally, Refractors and some other types of closed telescope OTAs may not need collimation. However, Reflector and Schmidt-Cassegrain (SCT) telescope need to be monitored to determine if they need collimation. Collimation procedures are quite different between [Reflector](#) and [SCT](#) telescopes. We will not dive into the details of the Mechanical Collimation process in this class since it is typically not necessary. We will perform collimation on the primary mirror since this is the component that needs collimation most often.

# Beginners Guide to Small Telescopes – Labs

## Performing Collimation

*Warning: Collimation is a process of small adjustments you can potentially damage your telescope if not performed properly. Over tightening collimation screws could cause the screws to snap or crack the mirror. For SCT's if you over loosen all of your collimation screws your primary secondary mirror could drop onto the primary mirror.*

Follow the steps outlined below to collimate your telescope (if required)

- Place a low power eyepiece in your telescope.
- Locate a bright star in the sky and center it in your field of view
- Defocus the star until you see a doughnut pattern.
- If the hole in the doughnut is perfectly centered your primary mirror is collimated. If not, you will need to adjust your collimation screws on your primary mirror (Reflectors) or Secondary Mirror (SCT) to push/pull the hole to the center of the doughnut. This process will move the doughnut off center from the field of view.
- Re-center the doughnut in the center of the field of view and re-evaluate to see if you need to make further adjustments to the collimation screws. Repeat the process of making adjustments and re-centering until the final result is a perfect doughnut centered in the field of view.
- Re-focus the star to a point of light. You have now collimated your telescope.

### SCT Collimation Screws

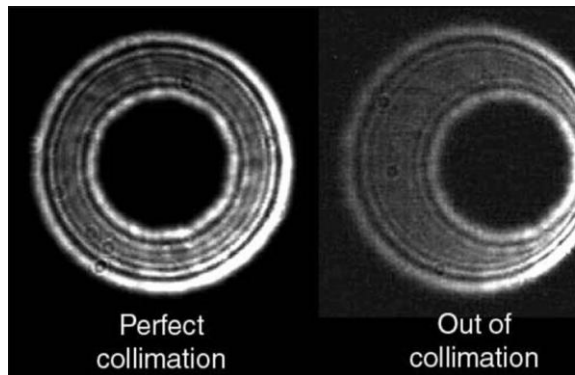

### Reflector Collimation Screws



# Beginners Guide to Small Telescopes – Labs

## Exercise 1: Plan Your Observation Session

identify 5 objects for your next observation session. This should include at least two deep-sky objects and two multiple star systems.

Object	Const	RA	DEC	Comments

## Observing Session

Tonight we will check collimation of your telescope and make appropriate adjustments to ensure your scope is collimated. We will then practice different techniques of location objects in the night sky.

- **Scope Setup** – Setup your telescope by performing the following steps:
  - Mount alignment
  - Finderscope alignment
- **Collimation**– Do not do this procedure until you have viewed the demonstration.
  - Locate a bright star in the sky that is conveniently placed for collimation.
  - Center the star in the telescope field of view and defocus the star image until a doughnut pattern is visible.
  - Inspect the image. If this the center hole in the doughnut is not centered in the rings of light the telescope needs to be collimated. Follow instructions on how to proceed with this process.
- **Techniques for finding objects** – We will try at least two techniques for locating objects:
  - **Star Hopping** – In this procedure a series of stars are located to locate an object
    - Using a star map or other reference determine a series of stars that can easily be followed to point you to your target object.
    - Locate hop from star to star to the final star and then proceed to utilize your telescope to center the target object.
  - **Setting Circles** – In this procedure we utilize the RA and DEC setting circles to locate objects
    - Locate a bright star in the general area of the target object. We will call this our reference star. Identify the star and determine what the RA and DEC coordinates are for the star
    - With a low power eyepiece, center the reference star in your telescope field of view.
    - Replace the low power eyepiece with a medium power eyepiece and re-center the reference star in the field of view.
    - Dial in the RA and DEC values for the star on the RA and DEC axis setting circles of your telescope.
    - Place the low power eyepiece back in the telescope and refocus.
    - Using your setting circles aim the OTA to the targeted object and see if it is in the field of view.

## Supplemental Resources

---















